

FR. INSTRUCTIONS D'ASSEMBLAGE EN. ASSEMBLY INSTRUCTIONS

PT. INSTRUÇÕES DE MONTAGEM
ES. INSTRUCCIONES DE ENSAMBLAJE
IT. ISTRUZIONI DI MONTAGGIO
DE. MONTAGEANLEITUNG
NL. MONTAGE-INSTRUCTIES

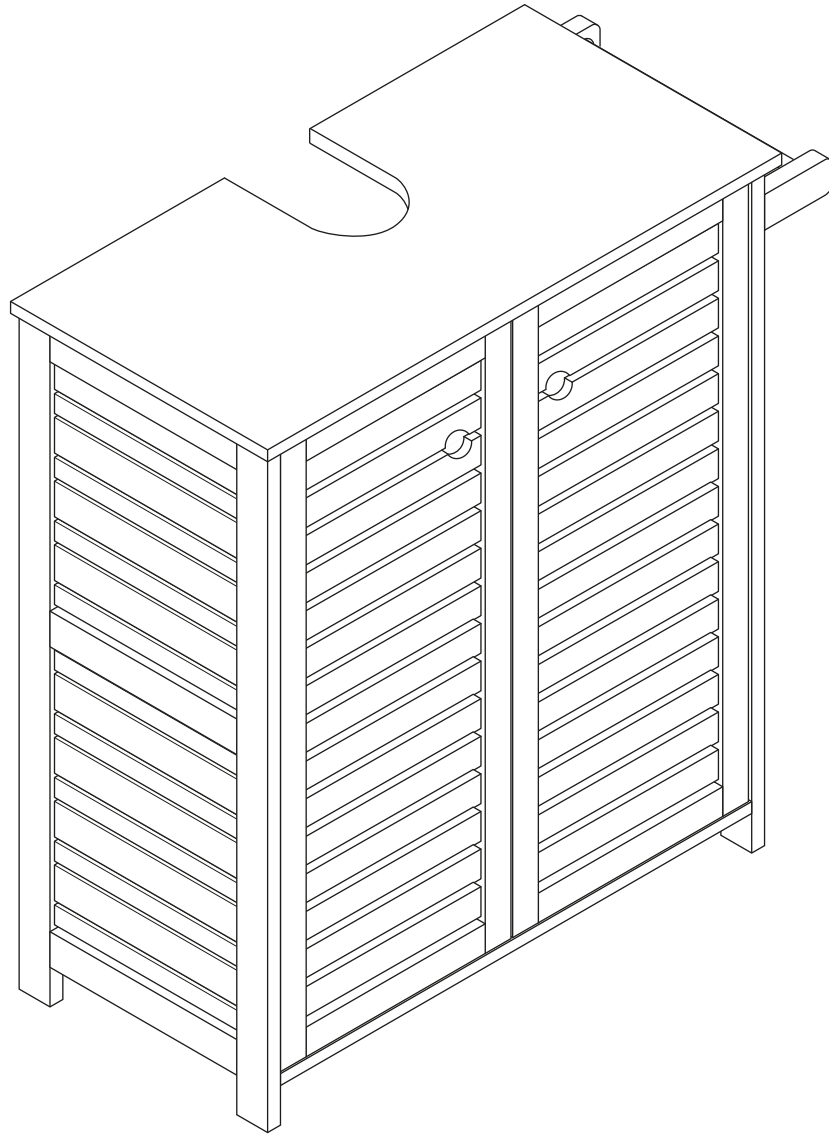

9900-764

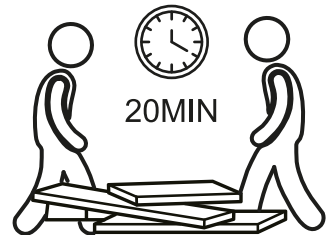
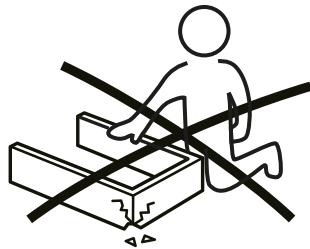
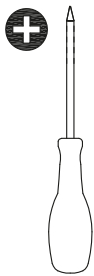

FR. INFORMATIONS À CONSERVER POUR CONSULTATION ULTÉRIEURE - À LIRE ATTENTIVEMENT
EN. INFORMATION TO BE RETAINED FOR FUTURE REFERENCE - READ CAREFULLY
PT. INFORMAÇÕES A SEREM MANTIDAS PARA CONSULTA FUTURA - LEIA ATENTAMENTE
ES. INFORMACIÓN A CONSERVAR PARA CONSULTA FUTURA - LEER ATENTAMENTE
IT. INFORMAZIONI DA CONSERVARE PER FUTURE CONSULTAZIONI - LEGGERE ATTENTAMENTE
DE. INFORMATIONEN ZUR SPÄTEREN NACHSCHLAGE - AUFMERKSAM LESEN
NL. INFORMATIE VOOR LATER BEWAREN - ZORGVULDIG LEZEN









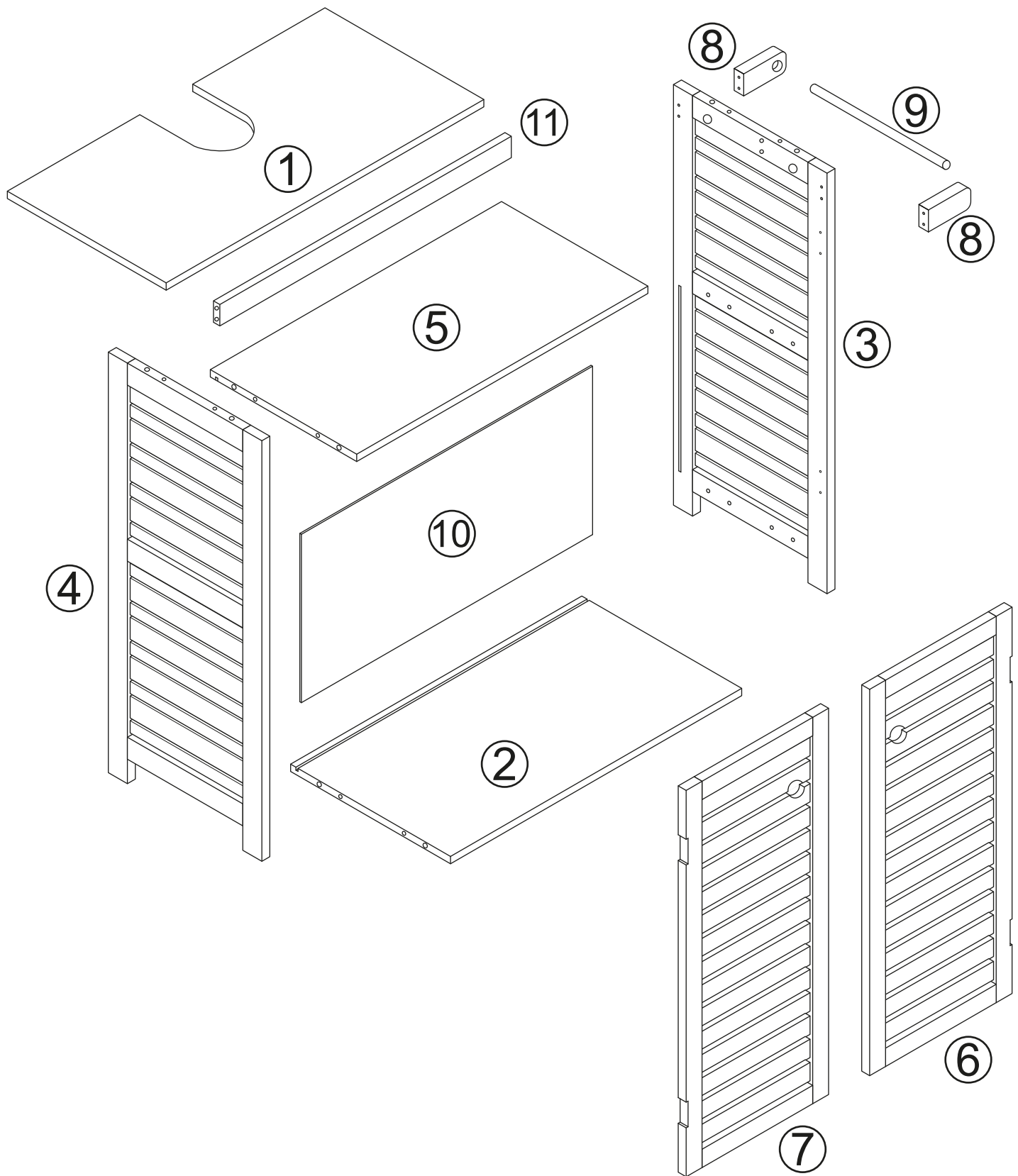

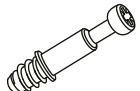
Importé par - Imported by - Importado por
Importato da - Importiert bei - Geïmporteerd door

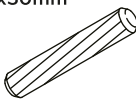
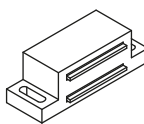
TENDANCE

27 boulevard des Etines 42120 LE COTEAU - FRANCE
TVA intracommunautaire N° FR38 500 766 324
www.tendance-bain.com

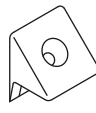
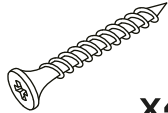

A 6x28mm  x12	B 15x10mm  x12	C 6x30mm  x16	D  x1	E 3x14mm  x6	F  x4
G 3x12mm  x18	H  x2	I  x4	J 4x35mm  x4	K  x4	2/8

1

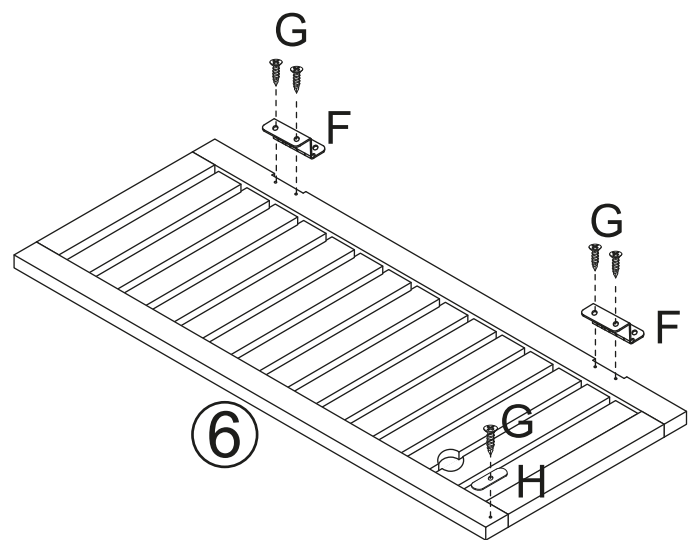
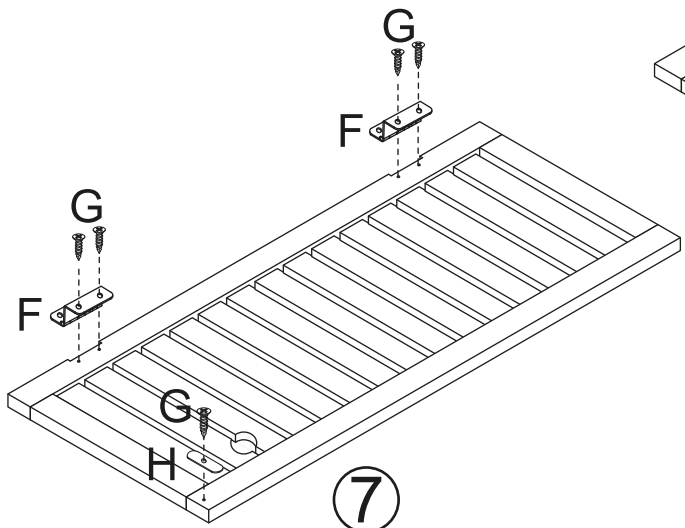
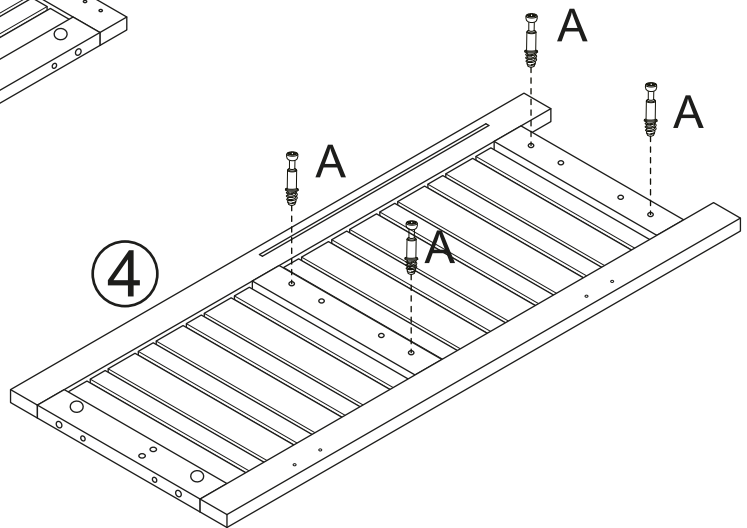
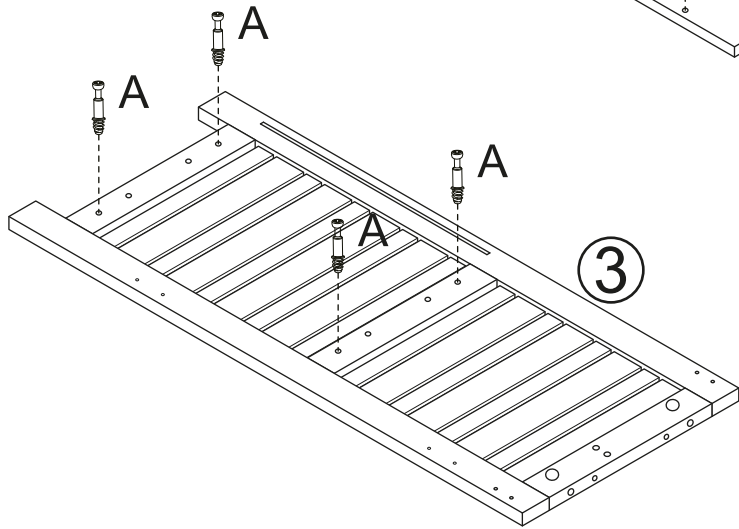
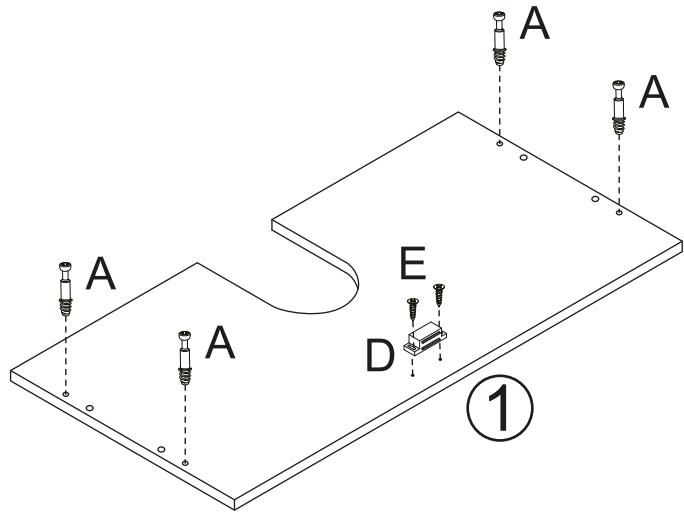

2

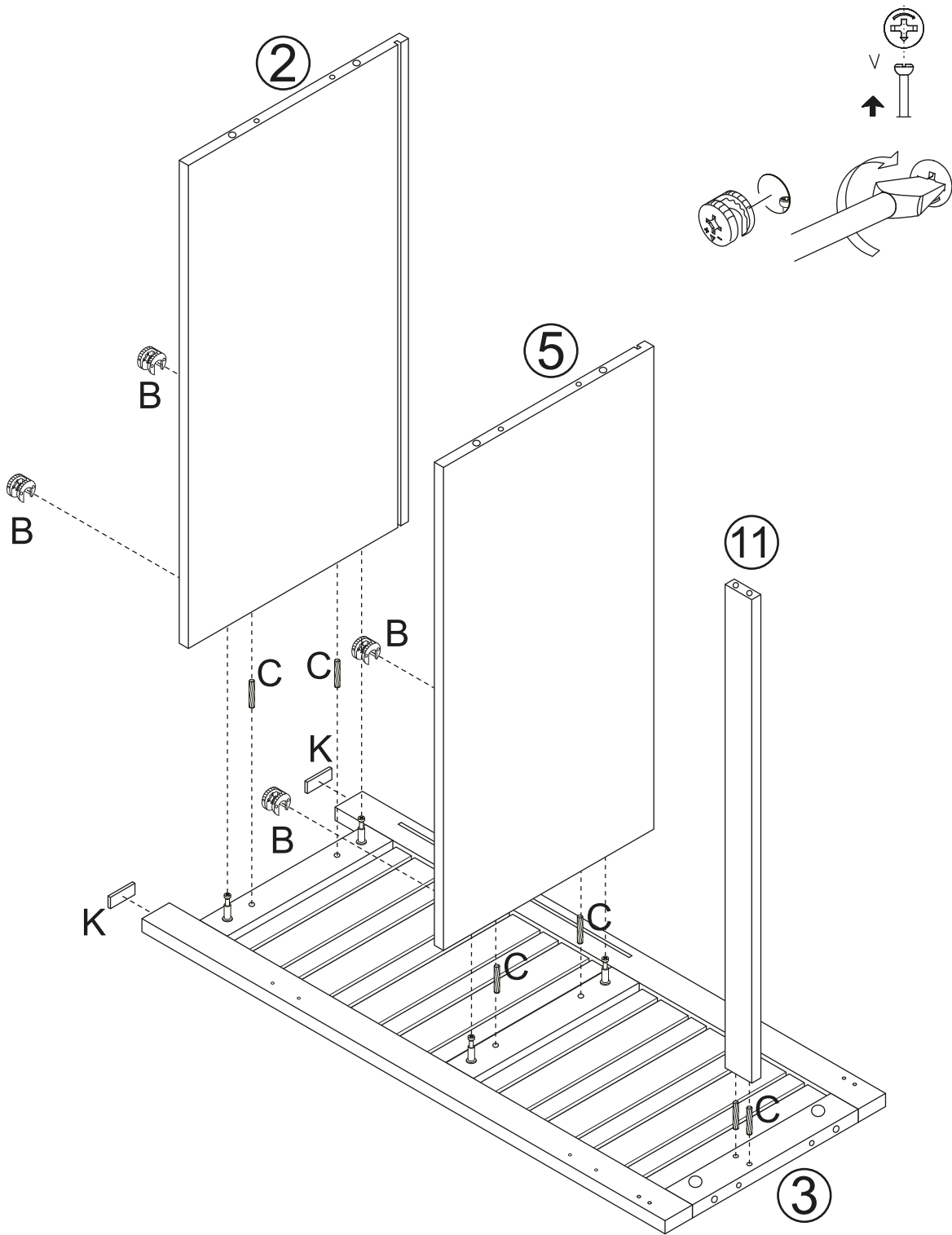

3

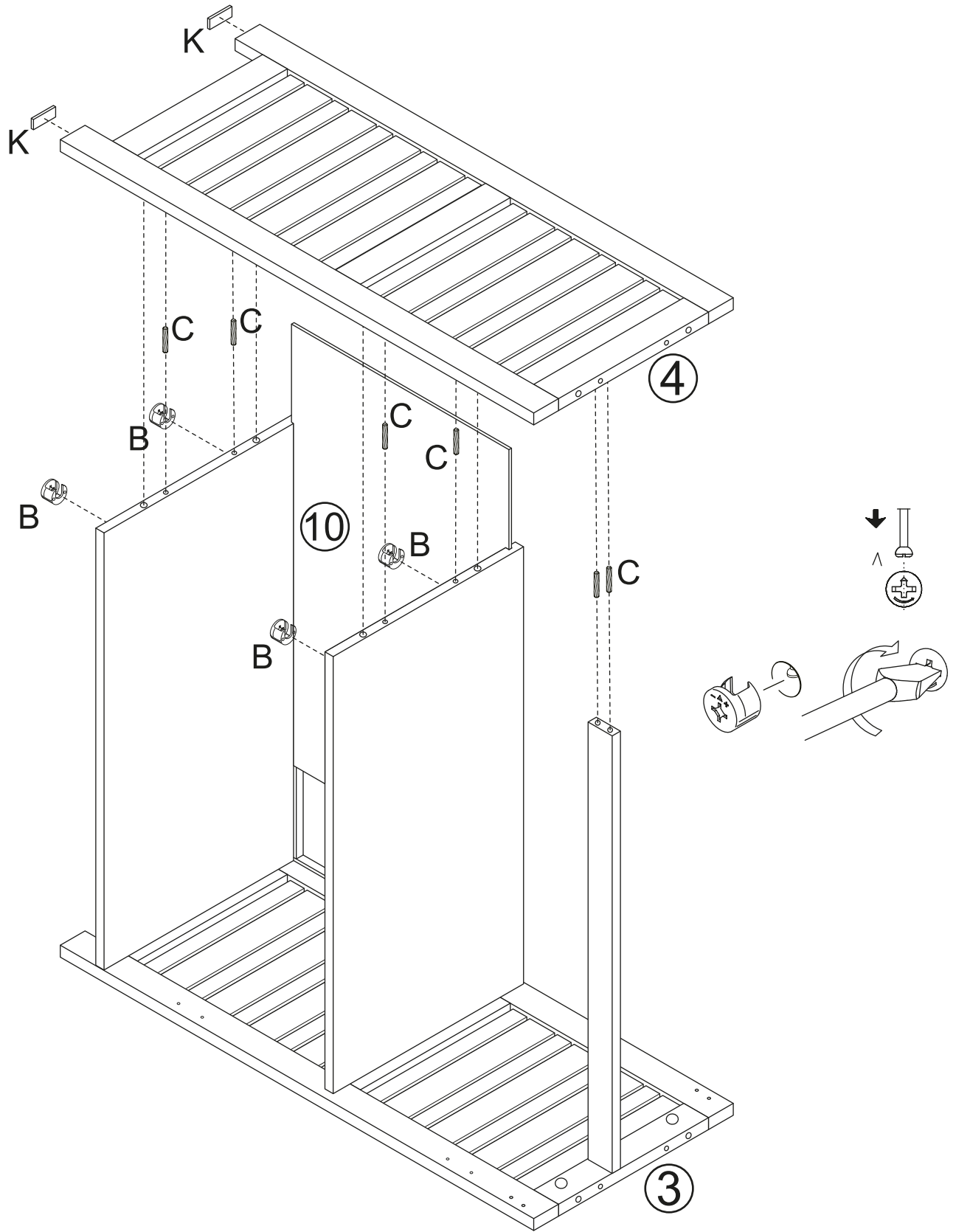

4

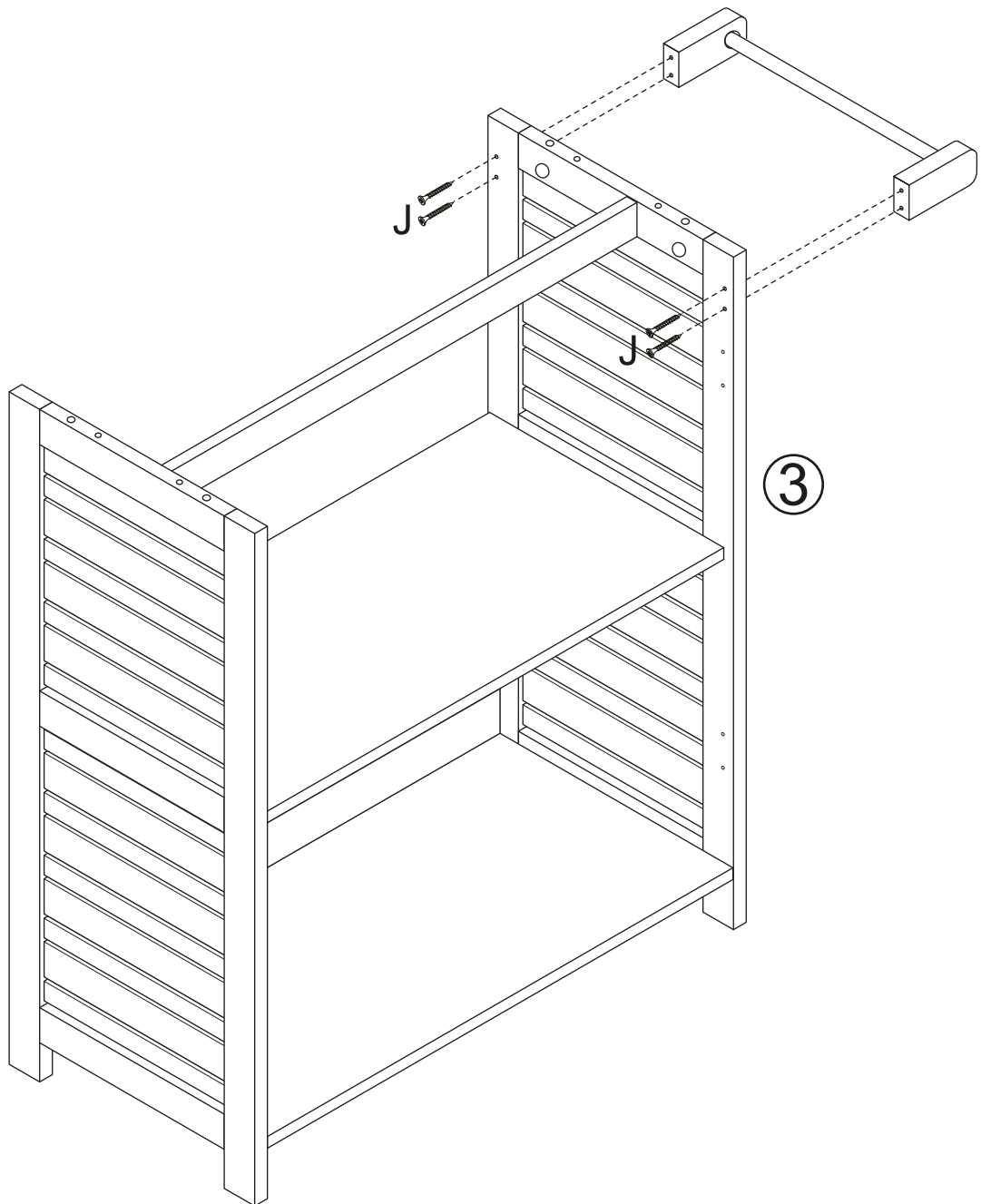
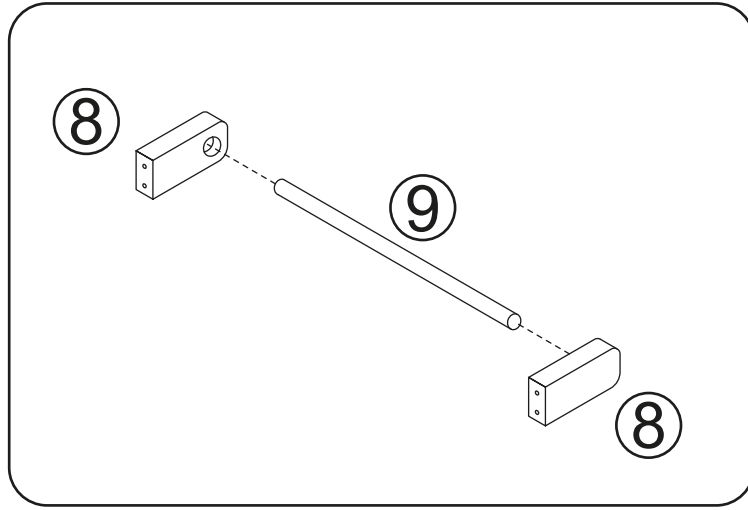

5

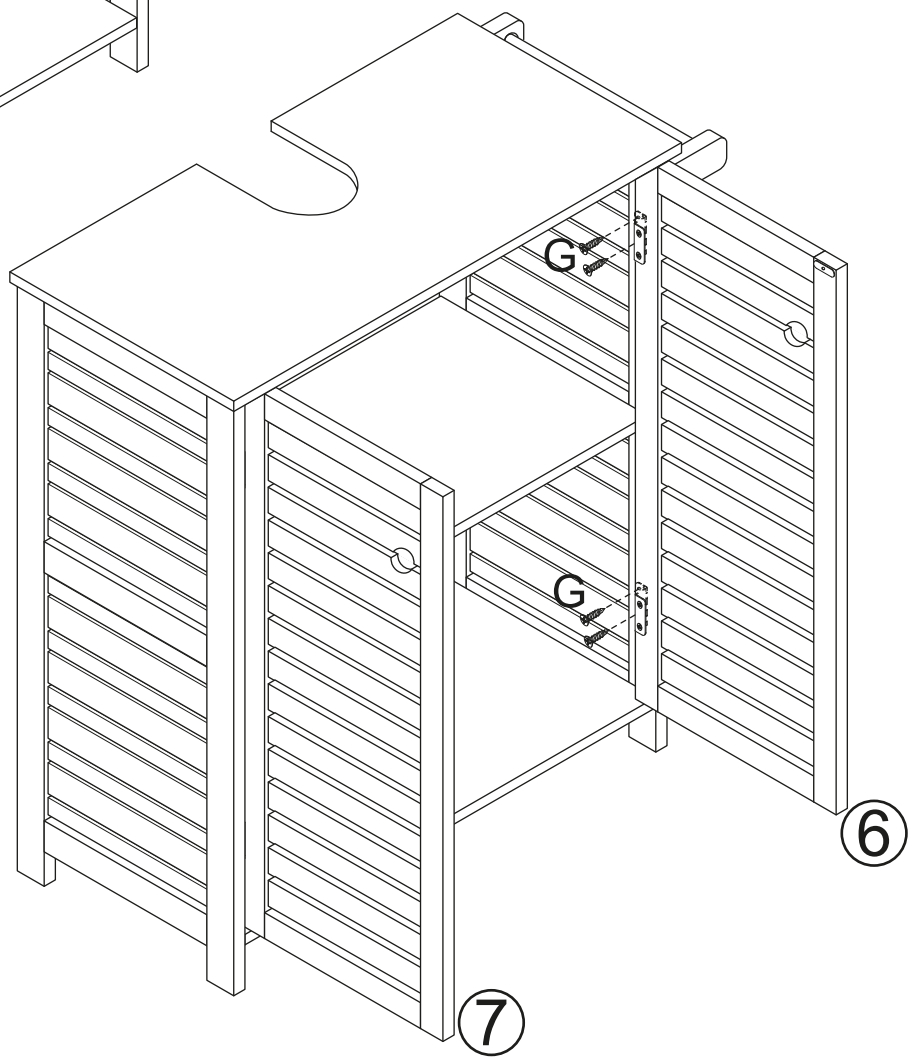
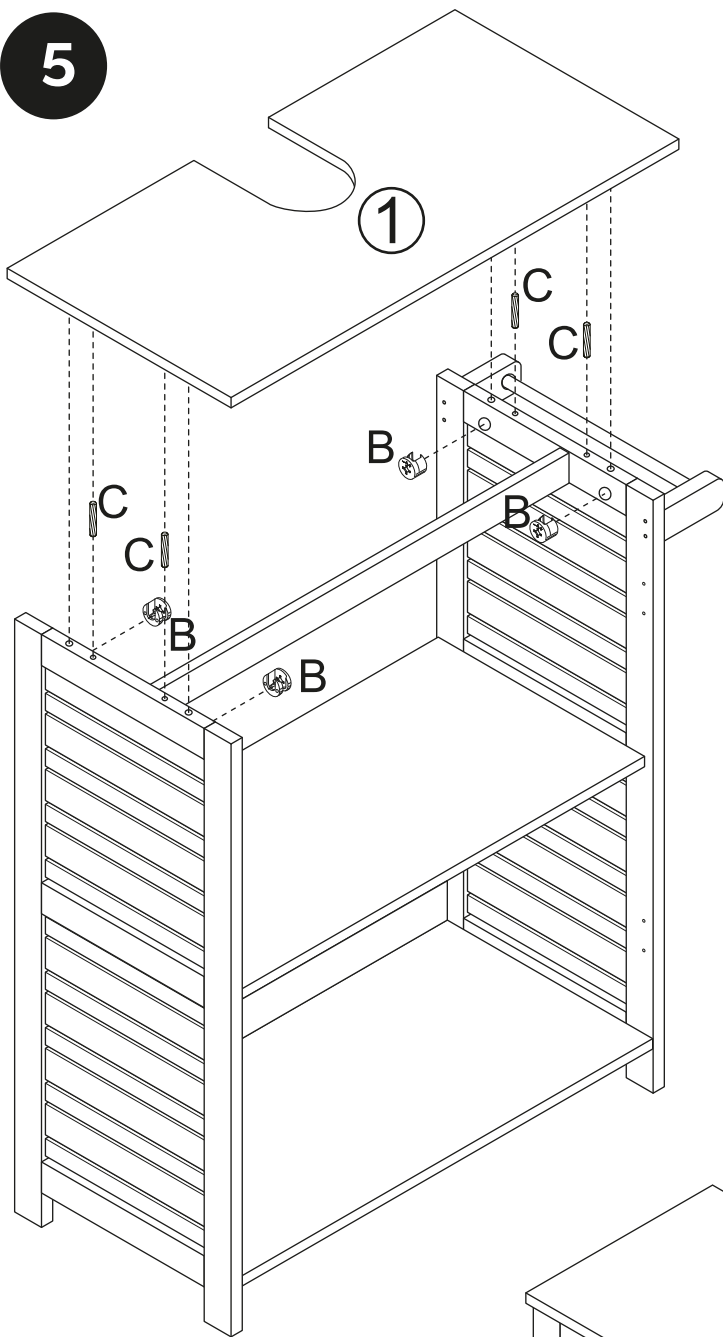

6

FR. Avant de fixer "I", s'assurer que la dimension "XX=YY"
EN. Before fix "I", please make sure size "XX=YY".
PT. Antes de corrigir "I", certifique-se de que o tamanho "XX = YY".
ES. Antes de corregir "I", asegúrese de que el tamaño "XX=YY".
IT. Prima di correggere "I", assicurarsi che la taglia "XX=YY".
DE. Bevor Sie "I" reparieren, stellen Sie bitte sicher, dass die Größe „XX=YY“ ist.
NL. Voordat u "I" repareert, zorg ervoor dat maat "XX=YY" is.

